

ITEM NO.	QTY.	SW-File Name (File Name)	DESCRIPTION	Comment 2
1	1	2105060-01-501	Drive Shaft 14/7 mm; Standard	L=3230
2	1	28 933	Hirschmann Set STAK/STAS-3 (Stak/Stas/clamp)	
3	1	58 957 99 11	Exterior Motor kit for 7:1 Hard Wired (incl. Motorhood L=545)	L=545 (Motorhood)
4	1	58 988	Stak/Stas Protecting Kit (incl. Tube, Plugs & Bracket) (lg=250mm)	
5	*400*	939	DIN 7981 Panhead screw 3.5 x 13	
6	*2*	939	DIN 7981 Panhead screw 3.5 x 9,5	
7	1	28 102	Somfy LS40 VULCAN Motor 13/10/230V, 3m white cable	
8	2	2105060-01-201	Edge Rack Arm, 35 mm	L=1100
9	59	88 300	Turnable Edge Pivotal Kit S-System Pitch-70/90 (incl. short slot clip & screw)	
10	2	2105060-01-100	Standard Rack Arm, 35 mm, Pitch 90 (10) Assembled	L=2430; Pitch 90 (10)
11	12	58 623	Omega H-55, 29x54,31x54x29 x 3 mm, lg=20mm	L=20
12	*68*	901	DIN 933 Hexagon Head Bolt M6x16	
13	*68*	908	DIN 125-1A Plain Washer M6	
14	*68*	910	DIN 934 Hexagon Nut M6	
15	*68*	911	DIN 6798-A Lock washer M6	
16	1	2105060-01-502	Drive Shaft 14/7 mm; Standard	L=3385
17	4	58 203	Rack Arm Connector End-Strip, 3 holes (M6), 20x3mm, lg=190mm	L=190
18	34	2105060-01-403	107e Louver	L=See DWG
19	2	2105060-01-202	Edge Rack Arm, 35 mm	L=1300
20	2	2105060-01-203	Edge Rack Arm, 35 mm	L=1300
21	6	58 305	Rack Arm Connector Center-Strip, 5 holes (M6), 20x3mm, lg=350mm	L=350
22	10	58 631	Omega H-55; 60°, lg=20mm	L=20 (60°)
23	2	2105060-01-100	Standard Rack Arm, 35 mm, Pitch 90 (10) Assembled	L=3060; Pitch 90 (10)
24	2	2105060-01-100	Standard Rack Arm, 35 mm, Pitch 90 (10) Assembled	L=1640; Pitch 90 (10)
25	34	2105060-01-404	107e Louver	L=See DWG
26	2	2105060-01-100-Slave	Standard Slave Rack Arm, 35 mm, Pitch 90 (10) Assembled	L=270; Pitch 90 (10)
27	2	2105060-01-100-Slave	Standard Slave Rack Arm, 35 mm, Pitch 90 (10) Assembled	L=1080; Pitch 90 (10)
28	4	58 724	Top plate 70 x 90 mm, 4 holes, S-System	
29	2	2105060-01-100	Standard Rack Arm, 35 mm, Pitch 90 (10) Assembled	L=840; Pitch 90 (10)
30	2	2105060-01-204	Edge Rack Arm, 35 mm	L=820

ATTENTION

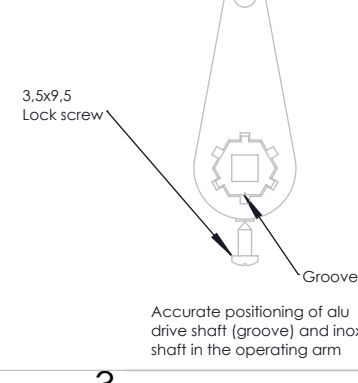

FASTENERS FOR INSTALLATION EXCLUDED (third party) FASTENERS FOR SYSTEM ASSEMBLY INCLUDED

CUSTOMER	DATE	22-9-2021	RACK ARMS & PARTS	Nat. gno
DESCRIPTION	SCALE	1:12.5	LOUVERS	RAL 9006
PROJECT NR	ENGINEER	SD	PLASTIC PARTS	Light Gray
Drawn by: NL 4941 V1	QTY	107E	Int	2105060-01-000
Approved by: REV 02	STATE	Approved	REV	24 A0

UNIQUE LOUVERS

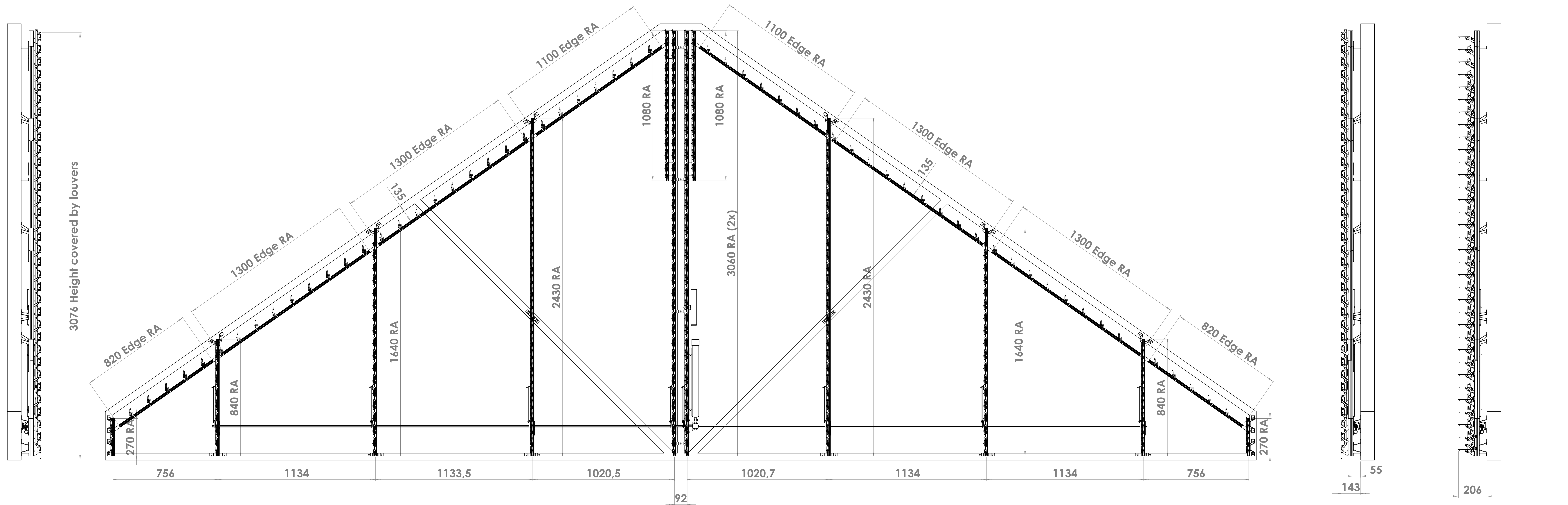
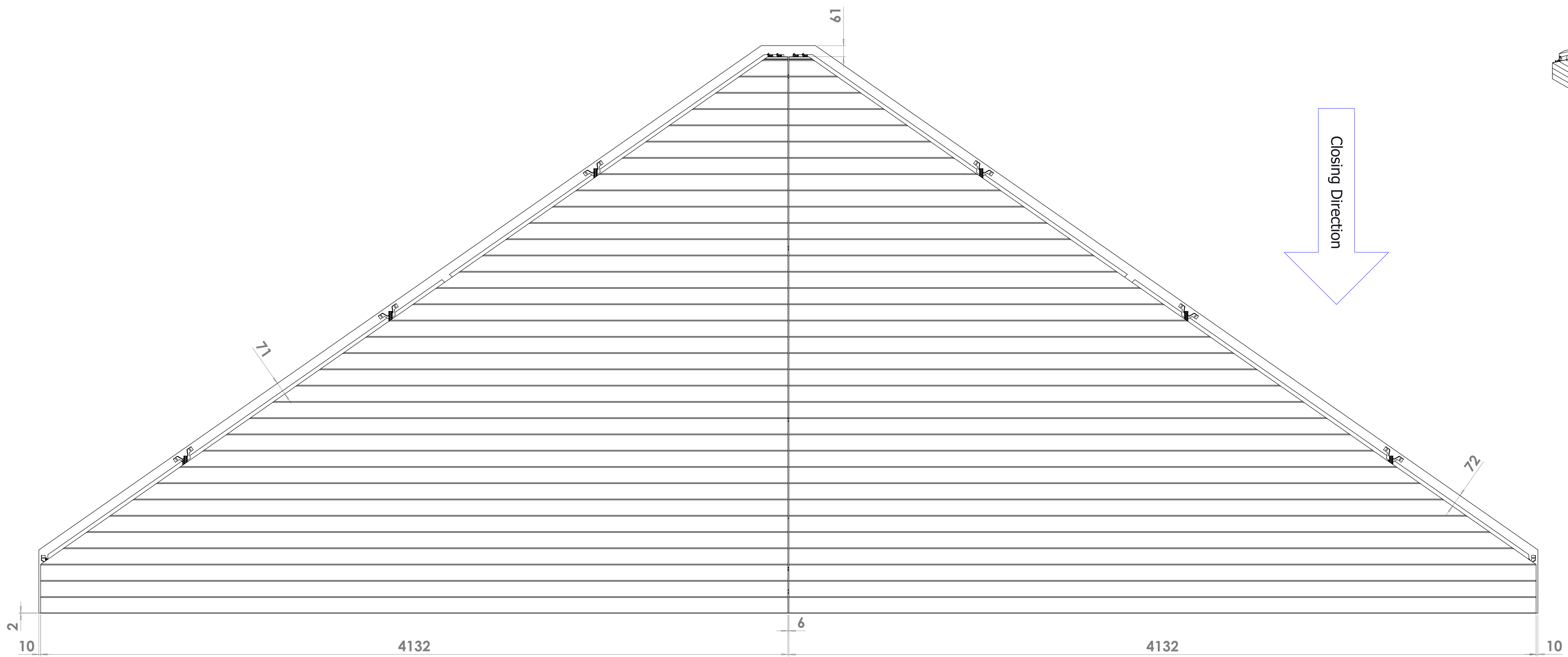

ATTENTION

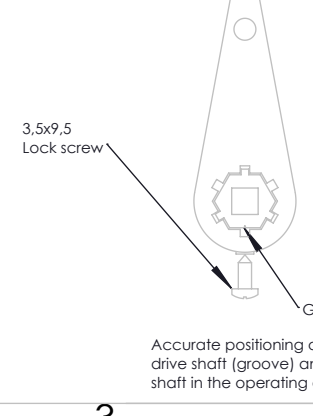

FASTENERS FOR INSTALLATION EXCLUDED (third party)				FASTENERS FOR SYSTEM ASSEMBLY INCLUDED			
MATERIAL				RACK ARMS & PARTS			Not. cno
CUSTOMER	DATE	22-9-2021		LOUVERS			RAL 9006
DESCRIPTION	SCALE	1:10		PLASTIC PARTS			Light Gray
PROJECT NR	ENGINEER	SD					
2105060	QTY	1					
2105060-01-000	STATE	Approved					
	REV	02					



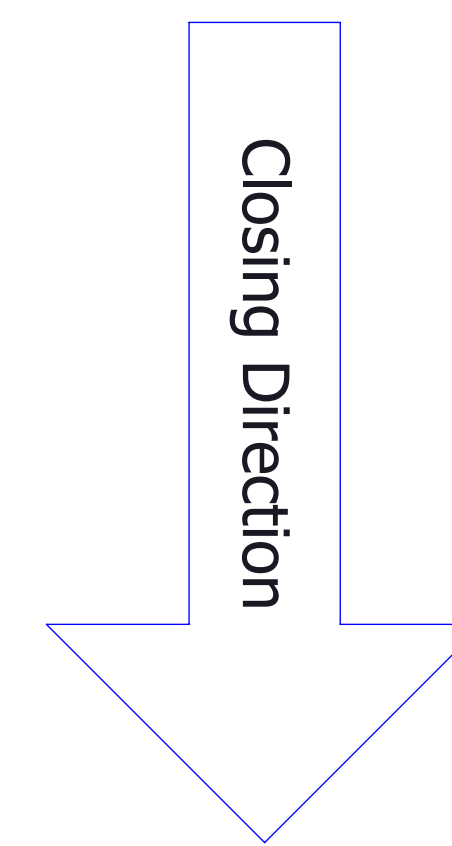
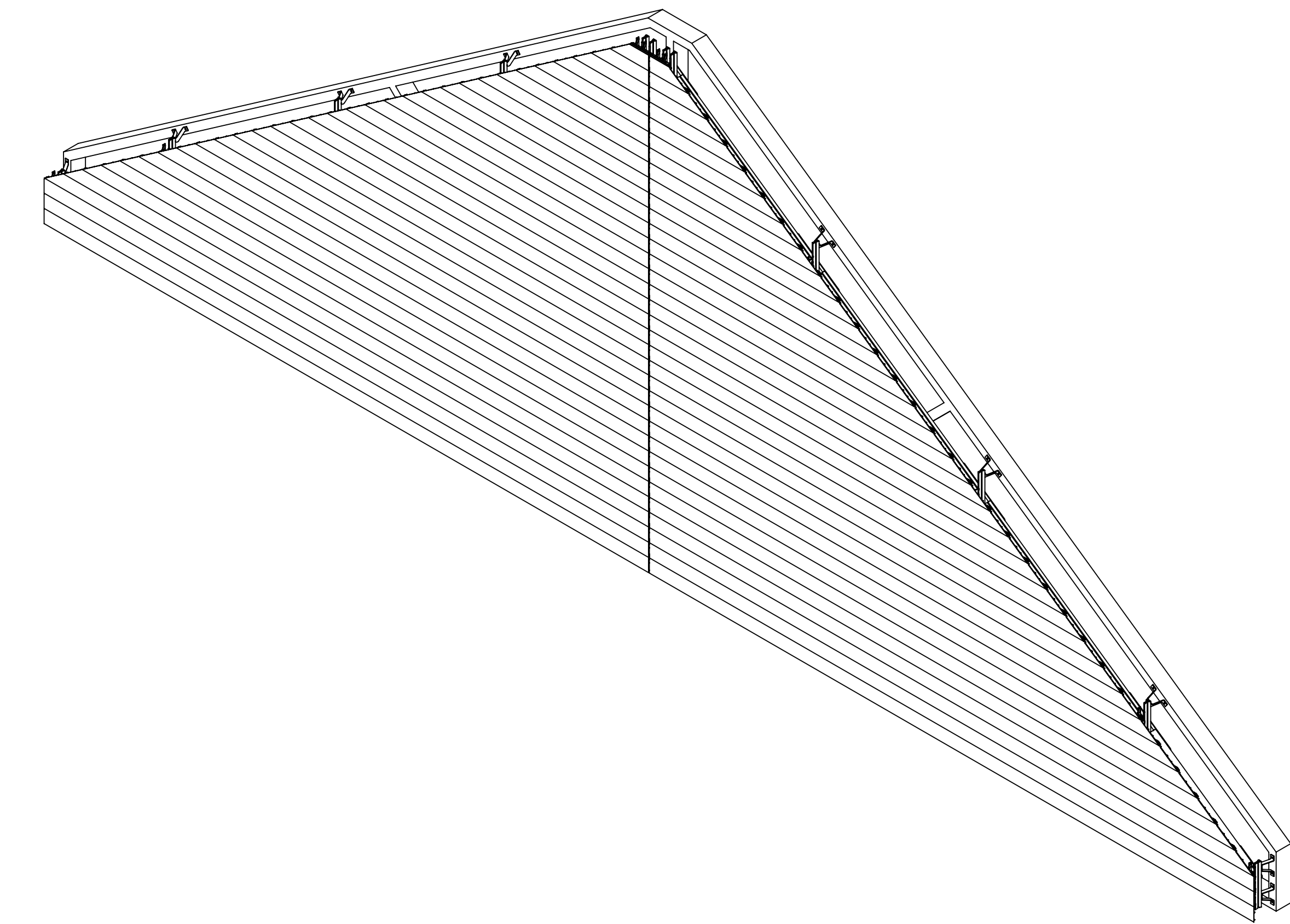
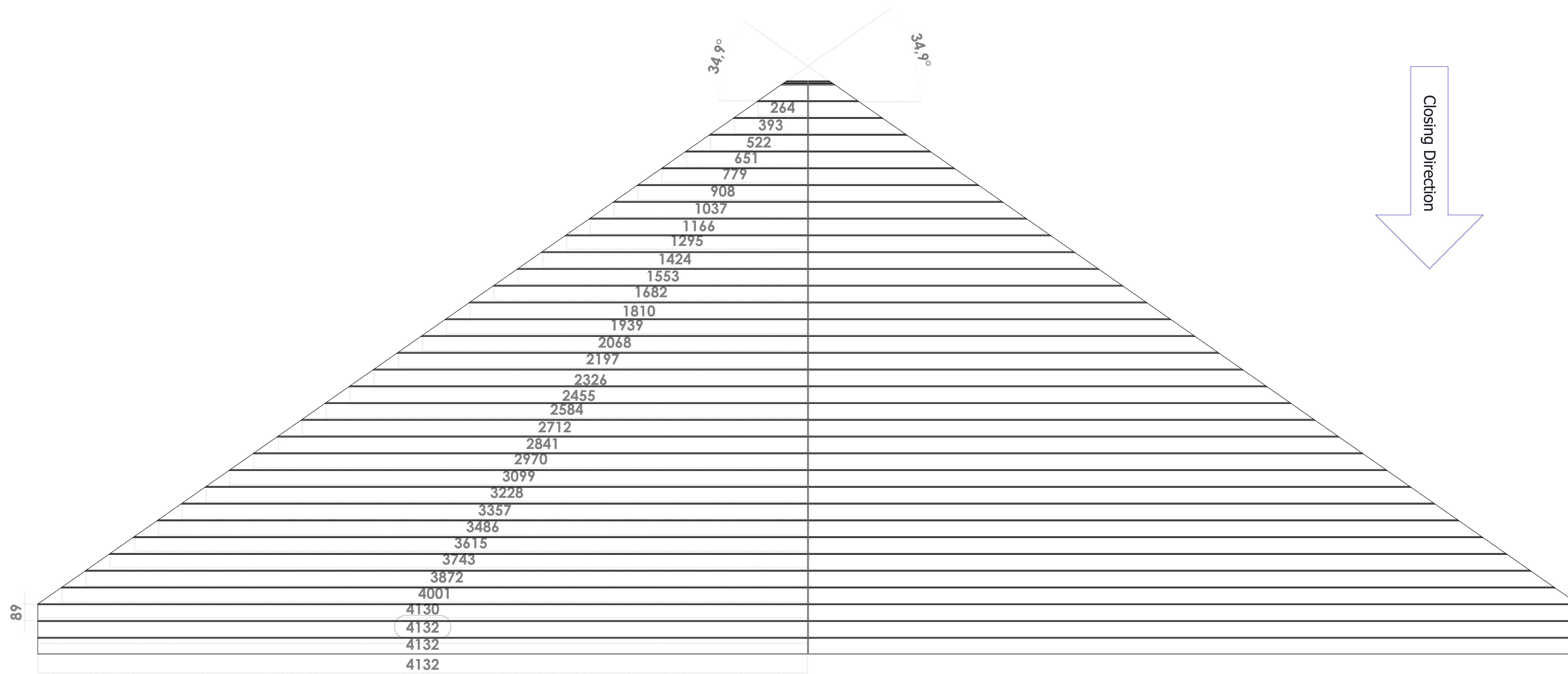

Right = Mirror Left

ATTENTION

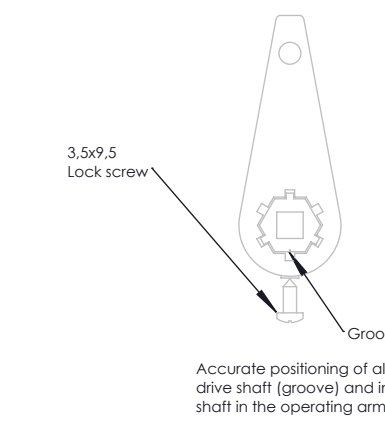

FASTENERS FOR INSTALLATION EXCLUDED (third party)				FASTENERS FOR SYSTEM ASSEMBLY INCLUDED			
MATERIAL							
CUSTOMER	DATE	22-9-2021	RACK ARMS & PARTS	Not. ano			
DESCRIPTION	SCALE	1:10	LOUVERS	RAL 9006			
PROJECT NR	ENGINEER	SD	PLASTIC PARTS	Light Gray			
2105060							
Quantity of	QTY	STATE	Approved	107E	Int	2105060-01-000	4/4 A0
NI 4941 V1							
Revision of	REV	02					
the description							
is not to be							
used without							
written consent							
of the							
responsible							

